

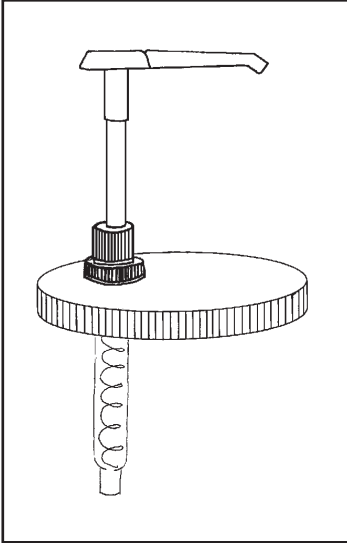

## 905 1-oz. Plastic Pump Kit



### description

- includes plastic cap sizes 89mm, 110mm, 120mm, and 904 econo dispensing pump
- FDA and USDA compliant for food applications and disinfectants
- for use with various neck sizes on different gallon containers
- great for food service and other institutional uses

Item	Description	Color/Scent	Size	Private Labeling	Case Weight	Case Cube	Packaging
905	1-oz. Plastic Pump Kit	white	10-3/4" L; various caps	NA	8 lbs	1.36	24/cs.

 inner case only  
 master carton only  
 no symbol indicates sold by the each