

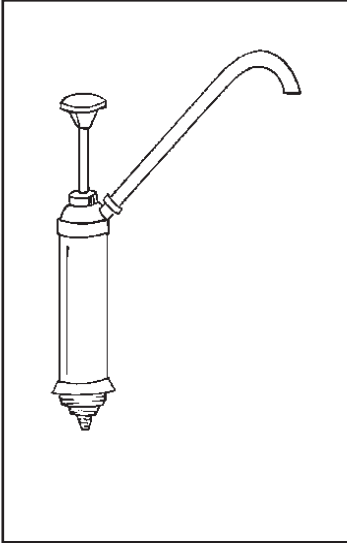

## 2200 / 2202 8-oz. Drum Pump



### description

- adapts to both 3/4" and 2" National Pipe Thread; fits 5, 15, 20, 30, & 55-gallon drum with 2" National Pipe Thread
- polypropylene and polyethylene construction for chemical resistance
- special pail adapter included, fits 5 or 6-gallon pails with Senior Rieke FlexSpout
- pumps 8-oz., or 2, 4, or 6-oz.
- restriction clips included
- chemical resistant O-ring for better seal
- replacement parts available

Item	Description	Color/Scent	Size	Private Labeling	Case Weight	Case Cube	Packaging
2200	8-oz. Drum Pump	blue	11" L x 2" D	Available, s	12 lbs	1.5	12/cs.
2202	8-oz. Drum Pump	gray	11" L x 2" D	Available, s	12 lbs	1.5	12/cs.

 inner case only  
 master carton only  
 no symbol indicates sold by the each